

## Block Cylinder

single acting with/without spring return, double acting  
max. operating pressure 500 bar

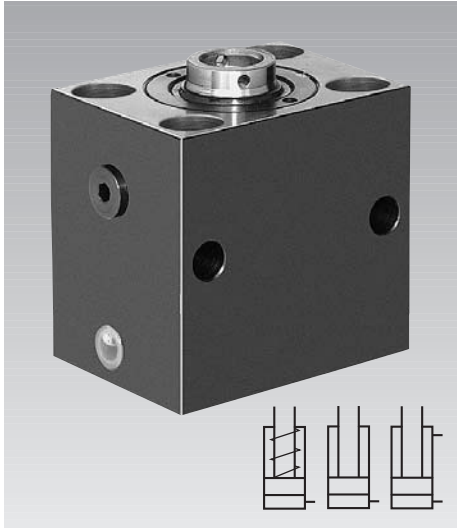

## Construction with RÖMHELD Block Cylinders

### The solution for many manufacturing tasks

The hydraulic block cylinders have been successfully used in thousands of hydraulic workholding applications. Block cylinders are also used as components in the construction of machines and moulds for functions like

Positioning  
Clamping  
Supporting  
Locking

Riveting  
Bending  
Opening  
Closing

Moving  
Swivelling  
Lifting  
Pulling

- **Large force range**  
Piston Ø 16 mm and 100 bar 2 kN  
Piston Ø 200 mm and 500 bar 1570 kN
- **Large stroke range 8-200 mm**
- **Position monitoring**  
– at the rear (see data sheet B 1.552)  
– laterally (see data sheet B 1.554)
- **Compact design**  
by large force density
- **Sealing with little leakage**
- **Many variants**  
and individual adaptation possibilities
- **Special versions**  
In cases where it does not seem possible to find a solution with the Römheld standard programme, there are numerous special versions available.  
Please contact us!
- **Operation of core pullers**

Variants available:  
♦ Shorter stroke  
♦ Keyway  
♦ Internal thread instead of mounting holes in the body

## On these data sheets there is the Römheld Block Cylinder Programme

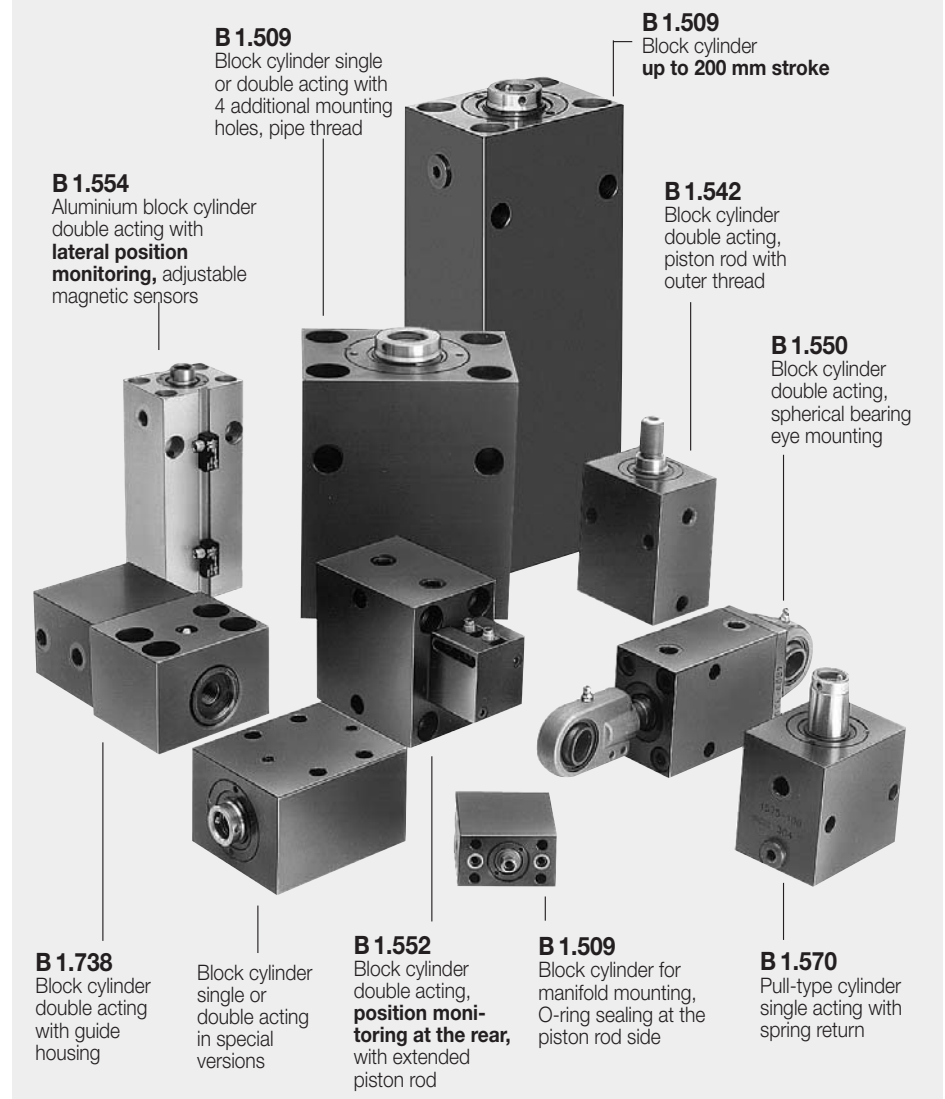



### Fixing possibility

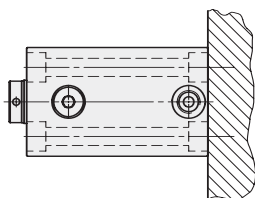
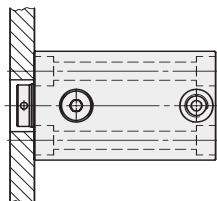
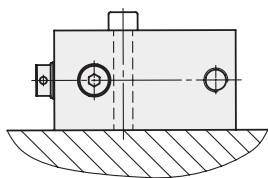

Cylinders must be backed up for operating pressures exceeding 160 bar

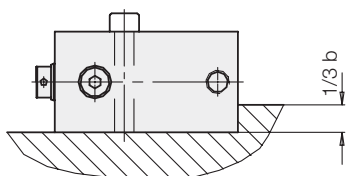

### Dimensions

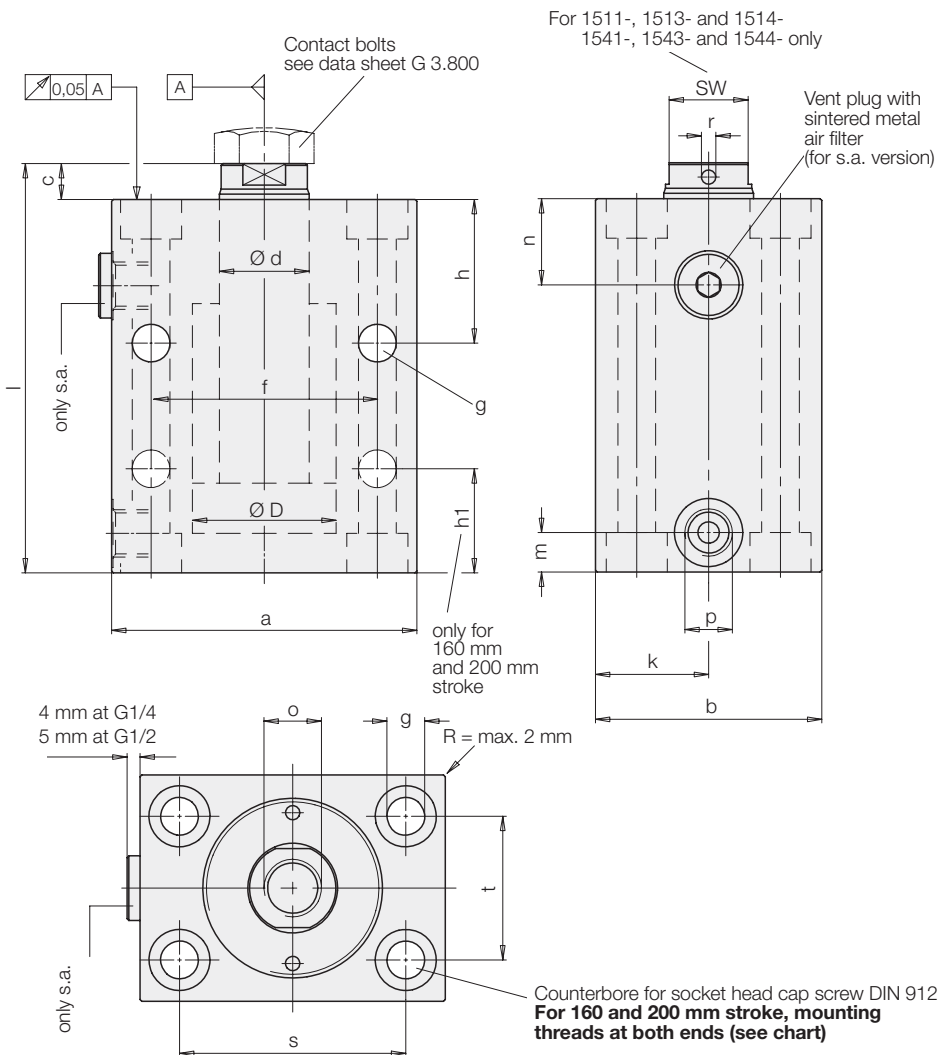

### Bleeding of the cylinder's interior of single-acting versions

If there is a possibility that cutting lubricants and coolants penetrate through the sintered metal air filter into the cylinder's interior, a vent hose has to be connected and be placed in a protected position, see data sheet A 0.110.

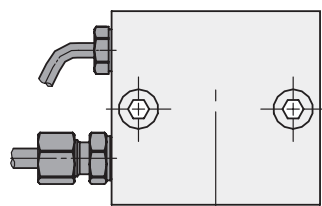

For this purpose the sintered metal air filter has to be exchanged by an insertion nipple fitting, see data sheet J 7.400, or a corresponding male connector, see data sheet F 9.300.

### General characteristics

Tolerances for length angle dimensions refer to DIN 7168-m

Piston material: casehardening steel, hardened

Cylinder body: high-alloy steel C 45 K

Operating conditions and other data see data sheet A 0.100.

### Type of connection / oil supply

● Pipe thread connection  
see page 2 + 3

● Manifold mounting with O-ring sealing  
see page 4

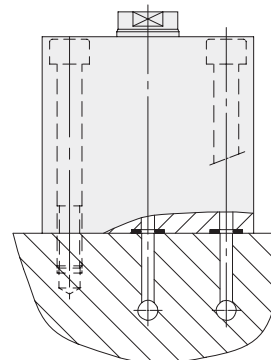
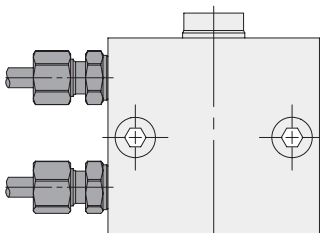



Piston Ø D	[mm]	16	25	32	40	50	63	80	100	125	160	200
Rod Ø d	[mm]	10	16	20	25	32	40	50	63	80	100	125
Force	100 bar [kN]	2.0	4.9	8.0	12.6	19.5	31.2	50.4	78.4	122.7	201	314
to push at	500 bar [kN]	10.0	24.5	40.2	62.8	98.5	156.0	252.0	392.0	613.5	1005	1570
Force	100 bar [kN]	1.2	2.9	4.9	7.7	11.6	18.6	30.6	47.4	72.4	122.5	191
to pull at	500 bar [kN]	6.1	14.5	24.5	38.3	57.9	93.0	153.2	236.8	362	612.6	957
Spring return force*, min.	[N]	50	140	195	270	410	430	760	1200	-	-	-
Oil volumen/10 mm stroke												
Stroke to extend	[cm³]	2.01	4.91	8.05	12.56	19.63	31.17	50.26	78.54	122.7	201	314
Stroke to retract	[cm³]	1.2	2.9	4.9	7.7	11.6	18.6	30.6	47.4	72.4	122.5	191
a	[mm]	60	65	75	85	100	125	160	200	230	300	380
b	[mm]	35	45	55	63	75	95	120	150	180	230	300
c	[mm]	6 (7)**	7	10	10	10	14	14	15	16	22	28
f	[mm]	30	50	55	63	76	95	120	158	180	230	300
g	[mm]	6.5	8.5	10.5	10.5	13	17	21	25	32	39	52
h	[mm]	30	33	38	40	44	50	60	64	82	92	112
k	[mm]	17.5	22.5	27.5	31.5	37.5	47.5	60	75	90	115	150
m	[mm]	11	11	11	11	13	17	21	25	31	39	51
n	[mm]	16.5	18	22	24	27	26	34	35	47	55	68
o x depth of thread	[mm]	M6x12	M10x15	M12x15	M16x25	M20x30	M27x40	M30x40	M42x60	M48x70	M56x80	M72x100
p		G1/4	G1/4	G1/4	G1/4	G1/4	G1/2	G1/2	G1/2	G1/2	G1/2	G3/4
r	[mm]	-	-	-	4	4	4	5	6	8	10	12
s	[mm]	40	50	55	63	76	95	120	158	180	230	300
t	[mm]	22	30	35	40	45	65	80	108	130	160	220
R	[mm]	2	2	2	2	2	2	2	-	-	-	-
SW	[mm]	8	13	17	-	-	-	-	-	-	-	-

### Single acting with spring return

<b>Stroke ±1</b>	[mm]	<b>8</b>	<b>8</b>	<b>10</b>	<b>10</b>	<b>12</b>	<b>12</b>	<b>12</b>	<b>12</b>	-	-	-
Total length l ±1	[mm]	62	71	85	89	100	116	131	145	-	-	-
Weight	[kg]	0.8	1.2	1.8	2.6	3.8	6.7	12.8	24.0	-	-	-
<b>Part-no.</b>		<b>1511-005</b>	<b>1513-005</b>	<b>1514-105</b>	<b>1515-005</b>	<b>1516-005</b>	<b>1517-005</b>	<b>1518-005</b>	<b>1519-005</b>	-	-	-
<b>Stroke ±1</b>	[mm]	<b>20</b>	<b>20</b>	<b>20</b>	<b>20</b>	<b>20</b>	<b>25</b>	<b>32</b>	<b>32</b>	-	-	-
Total length l ±1	[mm]	97	101	110	114	125	149	179	205	-	-	-
Weight	[kg]	0.86	1.9	2.7	3.6	5.25	9.75	19.8	37.0	-	-	-
<b>Part-no.</b>		<b>1511-025</b>	<b>1513-025</b>	<b>1514-125</b>	<b>1515-025</b>	<b>1516-025</b>	<b>1517-035</b>	<b>1518-045</b>	<b>1519-045</b>	-	-	-

### Single acting without spring return

<b>Stroke ±1</b>	[mm]	<b>16</b>	<b>20</b>	<b>25</b>	<b>25</b>	<b>25</b>	<b>30</b>	<b>32</b>	<b>40</b>	-	-	-
Total length l ±1	[mm]	62	71	85	89	100	116	131	145	-	-	-
Weight	[kg]	0.8	1.2	1.8	2.6	3.8	6.7	12.8	24.0	-	-	-
<b>Part-no.</b>		<b>1511-015</b>	<b>1513-015</b>	<b>1514-115</b>	<b>1515-015</b>	<b>1516-015</b>	<b>1517-015</b>	<b>1518-015</b>	<b>1519-015</b>	-	-	-
<b>Stroke ±1</b>	[mm]	<b>50</b>	<b>50</b>	<b>50</b>	<b>50</b>	<b>50</b>	<b>63</b>	<b>80</b>	<b>100</b>	-	-	-
Total length l ±1	[mm]	97	101	110	114	125	149	179	205	-	-	-
Weight	[kg]	0.86	1.9	2.7	3.6	5.25	9.75	19.8	37.0	-	-	-
<b>Part-no.</b>		<b>1511-065</b>	<b>1513-065</b>	<b>1514-165</b>	<b>1515-065</b>	<b>1516-065</b>	<b>1517-075</b>	<b>1518-085</b>	<b>1519-095</b>	-	-	-

### Double acting

<b>Stroke ±1</b>	[mm]	<b>16</b>	<b>20</b>	<b>25</b>	<b>25</b>	<b>25</b>	<b>30</b>	<b>32</b>	<b>40</b>	<b>40</b>	<b>40</b>	-
Total length l ±1	[mm]	62	71	85	89	100	116	131	145	166	190	-
Weight	[kg]	0.8	1.2	1.8	2.6	3.8	6.7	12.8	24.0	39	85	-
<b>Part-no.</b>		<b>1541-105</b>	<b>1543-105</b>	<b>1544-105</b>	<b>1545-105</b>	<b>1546-105</b>	<b>1547-105</b>	<b>1548-105</b>	<b>1549-105</b>	<b>1550-105</b>	<b>1551-005</b>	-
<b>Stroke ±1</b>	[mm]	<b>50</b>	<b>50</b>	<b>50</b>	<b>50</b>	<b>50</b>	<b>63</b>	<b>80</b>	-	-	-	-
Total length l ±1	[mm]	97	101	110	114	125	149	179	-	-	-	-
Weight	[kg]	0.86	1.9	2.7	3.6	5.25	9.75	19.8	-	-	-	-
<b>Part-no.</b>		<b>1541-165</b>	<b>1543-165</b>	<b>1544-165</b>	<b>1545-165</b>	<b>1546-165</b>	<b>1547-175</b>	<b>1548-185</b>	-	-	-	-
<b>Stroke ±1</b>	[mm]	<b>100</b>	<b>100</b>	<b>100</b>	<b>100</b>	<b>100</b>	<b>100</b>	<b>100</b>	<b>100</b>	<b>100</b>	<b>100</b>	<b>100</b>
Total length l ±1	[mm]	150	151	160	164	175	186	199	205	226	250	288
Weight	[kg]	1.6	3.1	4.5	5.6	8.15	13.2	22.8	37.0	54	110	-
<b>Part-no.</b>		<b>1541-195</b>	<b>1543-195</b>	<b>1544-195</b>	<b>1545-195</b>	<b>1546-195</b>	<b>1547-195</b>	<b>1548-195</b>	<b>1549-195</b>	<b>1550-195</b>	<b>1551-095</b>	<b>1552-095</b>
<b>Stroke ±1</b>	[mm]	-	<b>160</b>	<b>160</b>	<b>160</b>	<b>160</b>	<b>160</b>	<b>160</b>	<b>160</b>	<b>160</b>	<b>160</b>	<b>160</b>
Total length l ±1	[mm]	-	214	223	227	238	250	263	269	290	314	352
Thread x depth	[mm]	-	M8x12	M10x15	M10x15	M12x18	M16x24	M20x30	M24x36	M30x45	M36x54	M48x75
h 1	[mm]	-	26	27	27	30	41	47	54	66	77	95
Weight	[kg]	-	-	-	-	-	-	-	-	-	-	-
<b>Part-no.***</b>		-	<b>1543-110</b>	<b>1544-110</b>	<b>1545-110</b>	<b>1546-110</b>	<b>1547-110</b>	<b>1548-110</b>	<b>1549-110</b>	<b>1550-110</b>	<b>1551-110</b>	<b>1552-110</b>
<b>Stroke ±1</b>	[mm]	-	-	<b>200</b>	<b>200</b>	<b>200</b>	<b>200</b>	<b>200</b>	<b>200</b>	<b>200</b>	<b>200</b>	<b>200</b>
Total length l ±1	[mm]	-	-	263	267	278	290	303	309	330	354	392
Thread x depth	[mm]	-	-	M10x15	M10x15	M12x18	M16x24	M20x30	M24x36	M30x45	M36x54	M48x75
h 1	[mm]	-	-	27	27	30	41	47	54	66	77	95
Weight	[kg]	-	-	-	-	-	-	-	-	-	-	-
<b>Part-no.***</b>		-	-	<b>1544-111</b>	<b>1545-111</b>	<b>1546-111</b>	<b>1547-111</b>	<b>1548-111</b>	<b>1549-111</b>	<b>1550-111</b>	<b>1551-111</b>	<b>1552-111</b>

**Part-no. for version with FKM seals**  
15XX-XX6 FKM seals for temperatures  
over 100 °C until max. 150 °C

\* only for version  
- single acting with spring return -  
\*\* at 1541-16X and 1541-19X  
1511-02X and 1511-06X

\*\*\* Version: FKM seals  
two additional cross holes (dimension h1)  
without mounting holes  
4 mounting threads at both ends (see chart)



## Oil supply and O-ring sealing at:

**broad side**  
"short stroke" (16-40)  
**K**

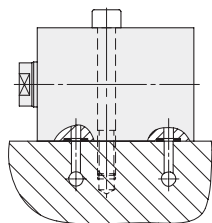

**broad side**  
"long stroke" (50 and more)  
**L**

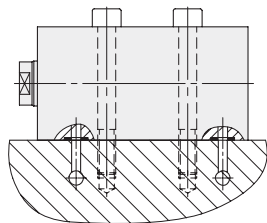

**rod side**  
**S\***

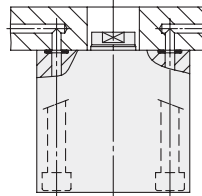

**bottom side**  
**B\***

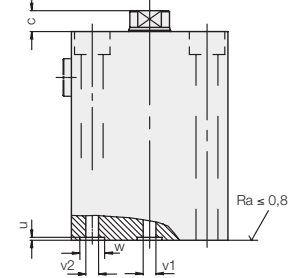
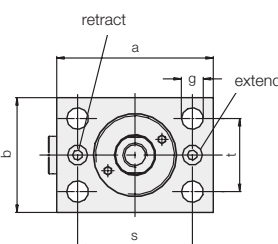
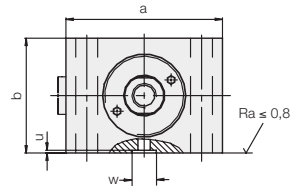
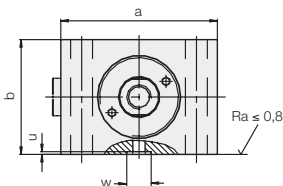
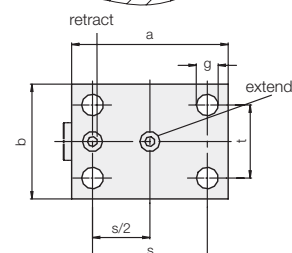
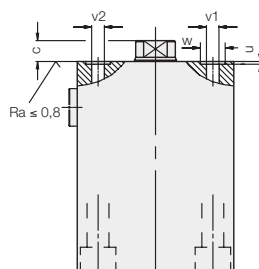
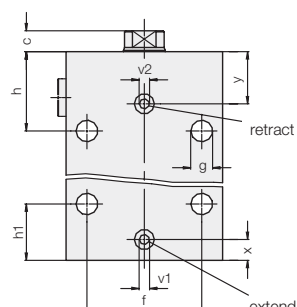
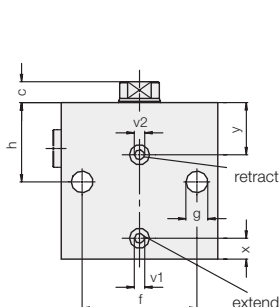
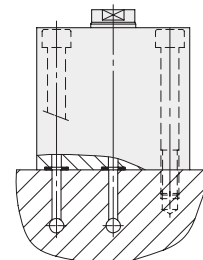

Block cylinder	15X1-XXX	15X3-XXX	15X4-XXX	15X5-XXX	15X6-XXX	15X7-XXX	15X8-XXX	15X9-XXX	1550-XXX
Piston Ø	16	25	32	40	50	63	80	100	125
Rod Ø	10	16	20	25	32	40	50	63	80
a	60	65	75	85	100	125	160	200	230
b	35	45	55	63	75	95	120	150	180
c	6	7	10	10	10	14	14	15	16
f	30	50	55	63	76	95	120	158	180
g	6.5	8.5	10.5	10.5	13	17	21	25	32
h	30	33	38	40	44	50	60	64	82
h1	24.5	26	27	27	30	41	47	54	66
s	40	50	55	63	76	95	120	158	180
t	22	30	35	40	45	65	80	108	130
u ± 0.05	1.1	1.1	1.1	1.1	1.1	1.5	1.5	1.5	1.5
v1 extend	3.5	4	5	6	6	8	8	8	8
v2 retract	3.5	4	4.5	4.5	6	6	8	8	8
w + 0.2	9.8	9.8	9.8	9.8	10.8	13.8	13.8	13.8	13.8
x	7	7.5	10	10	13	16	21	25	31
y	20.5	21	25	27	29.5	32	39	40	47
Dimensions O-ring	7 x 1.5	7 x 1.5	7 x 1.5	7 x 1.5	8 x 1.5	10 x 2	10 x 2	10 x 2	10 x 2
Part-no. O-ring	3000-342	3000-342	3000-342	3000-342	3000-343	3000-347	3000-347	3000-347	3000-347
Part-no. O-ring (FKM)	3001-077	3001-077	3001-077	3001-077	3000-275	3001-078	3001-078	3001-078	3001-078

\*Rework of existing cylinders S and B is not possible, because there are no cross holes. With strokes of 160 and 200 mm no longitudinal mounting holes, instead mounting thread at both ends (see chart, page 3). O-rings are included in delivery. Other dimensions see page 2 and 3. The following block cylinder versions are suitable for manifold mounting with O-rings: B 1.542, B 1.570, B 1.552 and B 1.554

### Order:

Please add the identification letters **K, L, S or B** to the part-no. of the required block cylinder.

#### 1. Example of ordering:

Double-acting block cylinder 1545-105 with oil supply at the broad side  
(For delivery without 4 mounting holes. Last digit 5 becomes 0)

**Part-no. 1545-100-K**

#### 2. Example of ordering:

Single-acting block cylinder 1513-025 with oil supply at the rod side

**Part-no. 1513-025-S**